

# Smoke Alarms

For minimum protection, install smoke alarms in each bedroom, outside each sleeping area, such as the hallway, and on every level of your home.

For maximum protection, install additional smoke alarms in each living area of your home.

Single Story Home

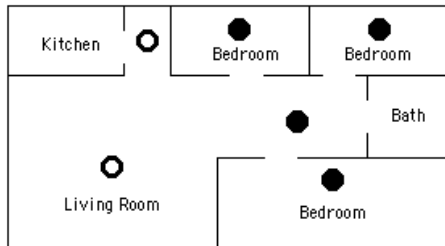

Two Story Home

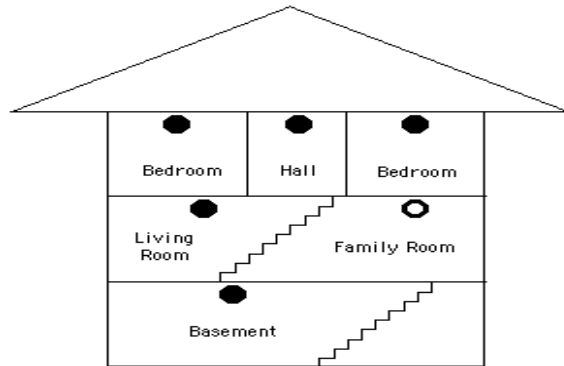

● = Smoke Detectors for Minimum Protection  
 ● + ○ = Smoke Detectors for Maximum Protection

If an alarm regularly responds to cooking smoke or shower steam, consider the following:

- Replace the alarm with one that has the silence button feature
- Move the alarm further away to give cooking smoke or steam a chance to dissipate before reaching the unit
- If ceiling mounted, move unit to a wall
- If the unit is the ionization type, replace it with a photoelectric detector. This type of alarm is less sensitive to smaller particles and thus less affected by cooking smoke or small amounts of steam. Packaging and/or owner's manual will indicate type of alarm.

## Installing Smoke Alarms:

- Mount smoke alarms in the middle of the ceiling if possible
- For wall-mounted units, place them at least 3' (1 m) from any corner and 4-6" (10-15cm) from the ceiling.
- Do not install smoke alarms near heating or cooling ducts
- In mobile home units, install smoke alarms on inside walls

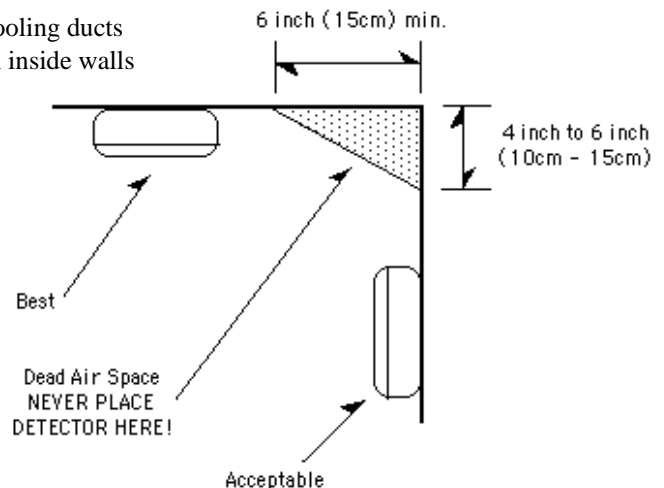

## Maintenance

**T**est smoke alarms every month. For hard to reach units, use a broom handle or stick to press the test button. Replace batteries once a year. Use daylight savings time as your reminder. "Change your clocks... change your batteries." If the low-battery signal begins to chirp, replace battery immediately. Vacuum the outside covers periodically to remove dust, dirt particles and insects.

**S**moke alarms monitor the air 24 hours a day, every day. After 10 years, it's been on the job for over 87,000 hours. For best protection, replace your smoke alarms every 10 years.

**D**o you remember when you installed your smoke alarms or how old they were when you moved in? If you are not sure, it is best to just replace them!

## Additional helpful links:

For more information about smoke alarms and specialized smoke alarms for the blind and hearing impaired, including talking, strobe (up to 177 candela), vibrating and amplified (up to 90 dB) smoke alarm products:

BRK Brands: [www.brkelectronics.com](http://www.brkelectronics.com)

First Alert: [www.firstalert.com](http://www.firstalert.com)

Gentex: [www.gentex.com](http://www.gentex.com)

Home Depot Supply: [www.hdsupply.com](http://www.hdsupply.com)

Kidde: [www.kiddeus.com](http://www.kiddeus.com)

MaxiAids (Provides a variety of products for special needs): [www.maxiaids.com](http://www.maxiaids.com)